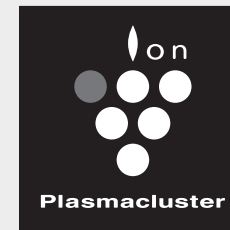

SHARP[®]

AIR PURIFIER

OPERATION MANUAL

Model

FU-D40A

High - Density 7000

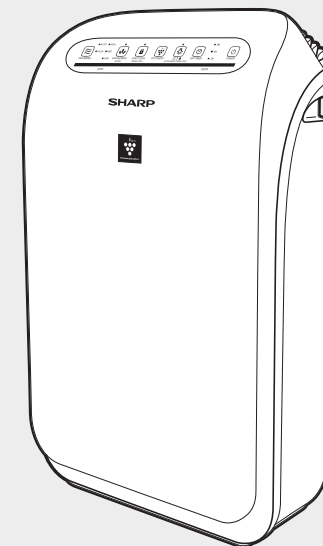

Thank you for purchasing the SHARP Air Purifier. Before any operation, please read this Operation Manual carefully so that you can use the air purifier correctly. Keep it in a safe place for future reference.



Device of this mark is a trademark of Sharp Corporation.
Plasmacluster is a registered trademark or a trademark of Sharp Corporation.

CONTENTS

PAGE

		PAGE
BE SURE TO READ	IMPORTANT SAFETY INSTRUCTIONS	E - 2
	PARTS NAME	E - 4
	BEFORE USE	E - 6
HOW TO USE	<ul style="list-style-type: none"> ● FILTER INSTALLATION ● PLACEMENT REQUIREMENTS 	
	HOW TO OPERATE	E - 8
	<ul style="list-style-type: none"> ● AIR PURIFICATION ● ION SHOWER 	
	EASY-TO-USE FUNCTIONS	E - 10
	<ul style="list-style-type: none"> ● PLASMACLUSTER ION ON/OFF ● CHILD LOCK ● INDICATOR LIGHT BRIGHT/DIM/OFF ● SENSOR SENSITIVITY ADJUSTMENT ● OFF TIMER 	
	CARE AND MAINTENANCE	E - 12
	<ul style="list-style-type: none"> ● REAR PANEL (PRE-FILTER) <ul style="list-style-type: none"> ● ROUTINE MAINTENANCE ● ON-DEMAND MAINTENANCE ● MAIN UNIT ● HEPA FILTER, ACTIVE CARBON DEODORIZING FILTER 	
	ADDITIONAL INFORMATION	E - 14
	<ul style="list-style-type: none"> ● FILTER PERFORMANCE ● TIPS FOR EFFECTIVE OPERATION 	
	FILTER REPLACEMENT	E - 15
<ul style="list-style-type: none"> ● HEPA FILTER, ACTIVE CARBON DEODORIZING FILTER 		
HOW TO TROUBLESHOOT	TROUBLESHOOTING	E - 16
SPECIFICATIONS	SPECIFICATIONS	E - 18

SHARP[®]
SHARP CORPORATION

IMPORTANT SAFETY INSTRUCTIONS Be sure to follow!

- This appliance is not intended for use by persons (including children) with reduce physical, sensory, or mental capabilities or lack of experience and knowledge, unless they have been given supervision or instruction concerning use of the appliance by a person responsible for their safety.
- Children should be supervised to ensure that they do not play with the appliance.

To prevent any possible injury to persons or damage to property, be sure to follow the basic safety precautions, including the following:

- The degree of injury or damage resulting from incorrect use or operation while ignoring the indicated matters is classified and explained with the following symbols.

	WARNING Indicates a potentially hazardous situation which, if not avoided, could result in serious injuries or even death.
	NOTE Indicates a potentially hazardous situation which, if not avoided, could result in injury to persons or damage to property.

- The precautions to be observed are indicated with the following symbols and signs.

	This symbol indicates a prohibited action.
	This symbol indicates a mandatory action.

WARNING To prevent fire, electric shock or injury.

Power plug, power cord

- Only use the power supply with a rated voltage of 220-240V (50/60Hz).
(Otherwise, fire or electric shock may be caused.)
- Do not damage, process, forcibly bend, pull by force, twist or bind the power cord.
(Otherwise, fire or electric shock may be caused.)
- Do not place heavy objects on the power cord, or apply too much force to it.
(Otherwise, fire or electric shock may be caused.)
- Do not use the product when the power cord or plug is damaged or the connection to the power socket is loose.
(Otherwise, fire, electric shock or short circuit may be caused.)
- Do not plug or unplug the power cord with wet hands.
(Otherwise, electric shock may be caused.)
- Do not attempt to replace the power cord on your own. If the power cord is damaged, contact Sharp authorized Service Center for replacement or repair.
- Clean the accumulated dirt on the power plug or power socket on a regular basis.
(Accumulated dust may result in poor insulation from humidity, etc., thereby causing fire or electric shock.)

Before maintenance

- Before any attempt to maintain, clean or move the product, be sure to shut it down and remove its power plug.
(Otherwise, electric shock or injury may be caused.)

In the case of an exception (e.g., burnt smell)

- Shut down the product and remove its power plug.
(Otherwise, smoke may be released, or fire, electric shock or injury may be caused.)
- Be sure to immediately shut down the product, remove its power plug and contact a Sharp authorized Service Center for repair.

Use

- Do not put fingers or sticks into the Air Outlet or Air Inlet.
(Otherwise, electric shock or malfunction may be caused.)
- Do not attempt to modify, disassemble or repair the product on your own.
(Otherwise, fire, electric shock or injury may be caused.)
For any repair, contact a Sharp authorized Service Center. Only qualified technicians can inspect or repair this product.
- Do not spill any liquid over the unit. Do not let any liquid enter the unit.
(Otherwise, electric shock, short circuit or fire may be caused.)
- Keep the unit out of the reach of children.
(Otherwise, electric shock or injury may be caused.)

NOTE

To prevent leakage and injury, and to protect against property loss

Power plug, power cord

- Be sure to unplug the power cord by holding the plug.
(Otherwise, fire, electric shock or short circuit may be caused.)
- When you are not using the product for a long time, be sure to unplug the power cord from the power socket.
(Otherwise, electric shock or fire may be caused due to poor insulation.)

Use

- Keep the product away from flammables, lit cigarettes or burnt incenses.
(Otherwise, fire may be caused.)
- Never clean the product with petrol or chemicals. Do not spray pesticide on it.
(Otherwise, surface crack, electric shock or fire may be caused.)
- Do not run the air purifier in a room where fumigation pesticides are used.
Pharmaceutical ingredients accumulated in the unit will come out from the air outlet after the unit is started, which is harmful to your health. Therefore, after using pesticides, fully ventilate the room before you start the unit.
- Do not sit or lean on the air purifier.
(This is because turnover may cause injury or malfunction.)
- Do not use the unit to store artwork or academic information.
Do not use the unit for business or other special purposes.
(Otherwise, the quality of stored data may be reduced.)
- Do not put the unit in unstable places.
Do not put the unit on inclined panels or in unstable or high places.
- Do not use the unit in a bathroom or places with much humidity and water.
(Otherwise, fire, electric shock or malfunction may be caused.)

- Before attempting to move the product, be sure to shut it down and tightly hold the handles on the both sides behind the main unit.

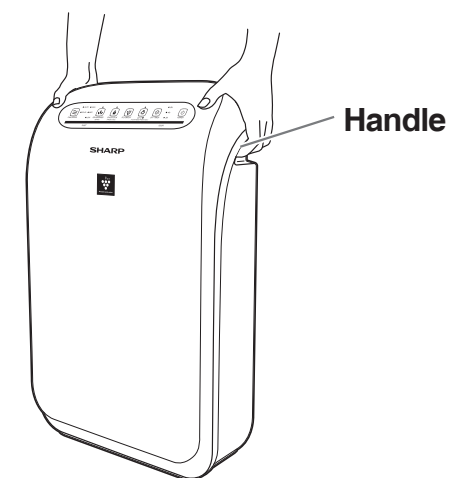

- When using the unit with a burning appliance, open the window a little to ventilate the room.
This product is not designed to remove harmful substances such as carbon monoxide.
(When ventilation is not sufficient, suffocation may be caused due to lack of oxygen.)

PARTS NAME

The device starts when the button with ★ is pressed.

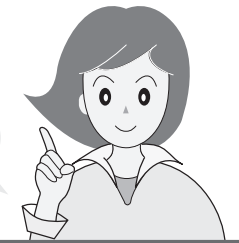

MAIN UNIT AND CONTROL PANEL

PARTS NAME

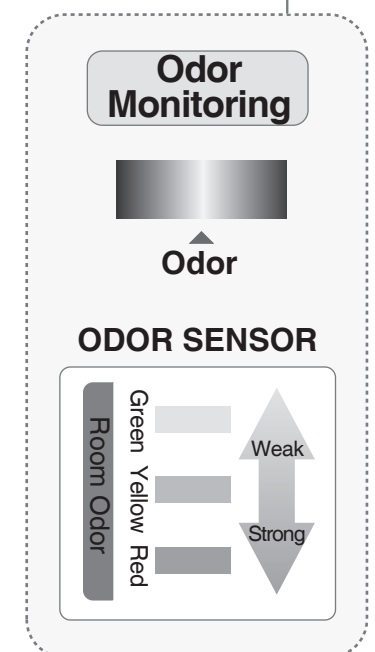
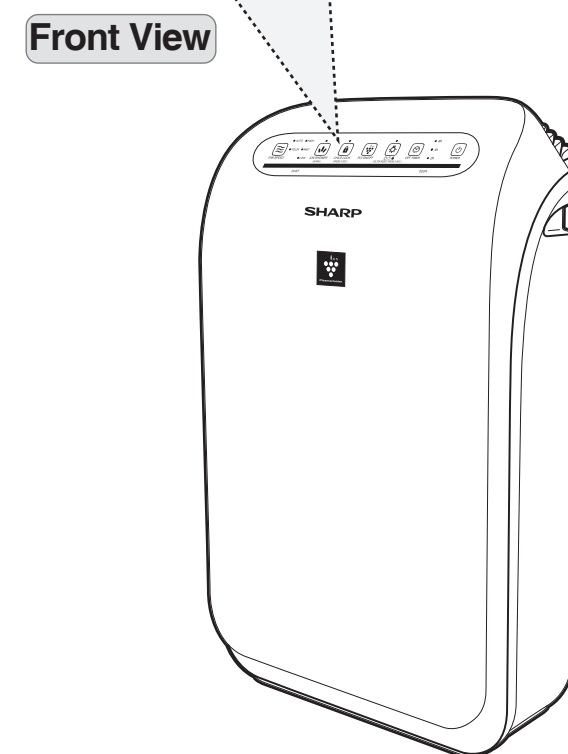
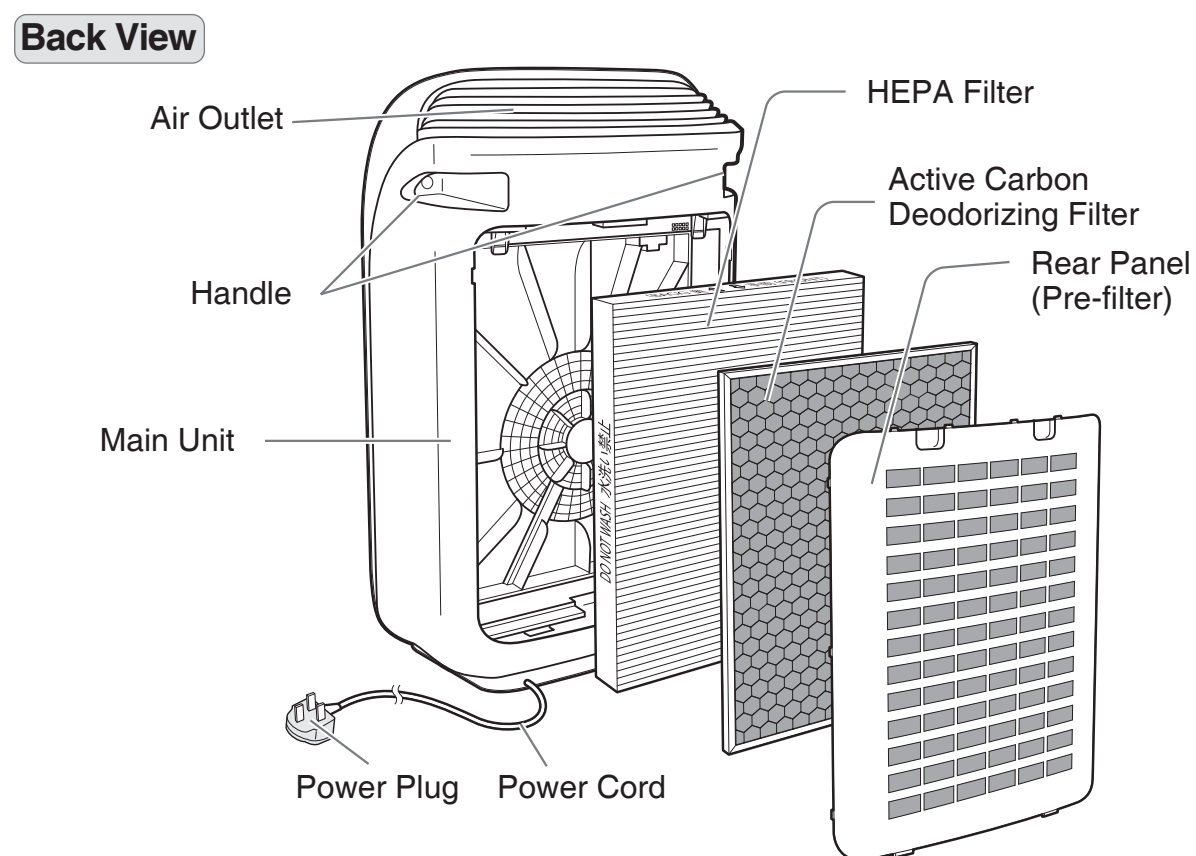
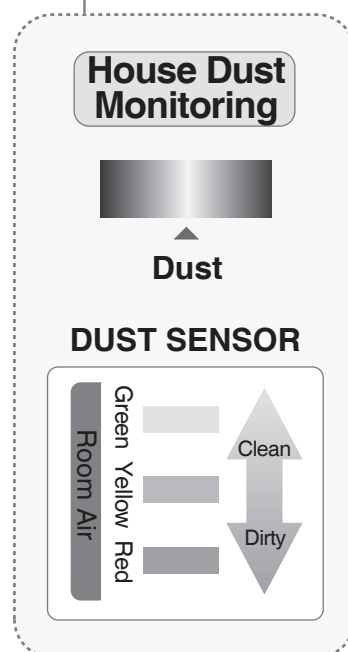
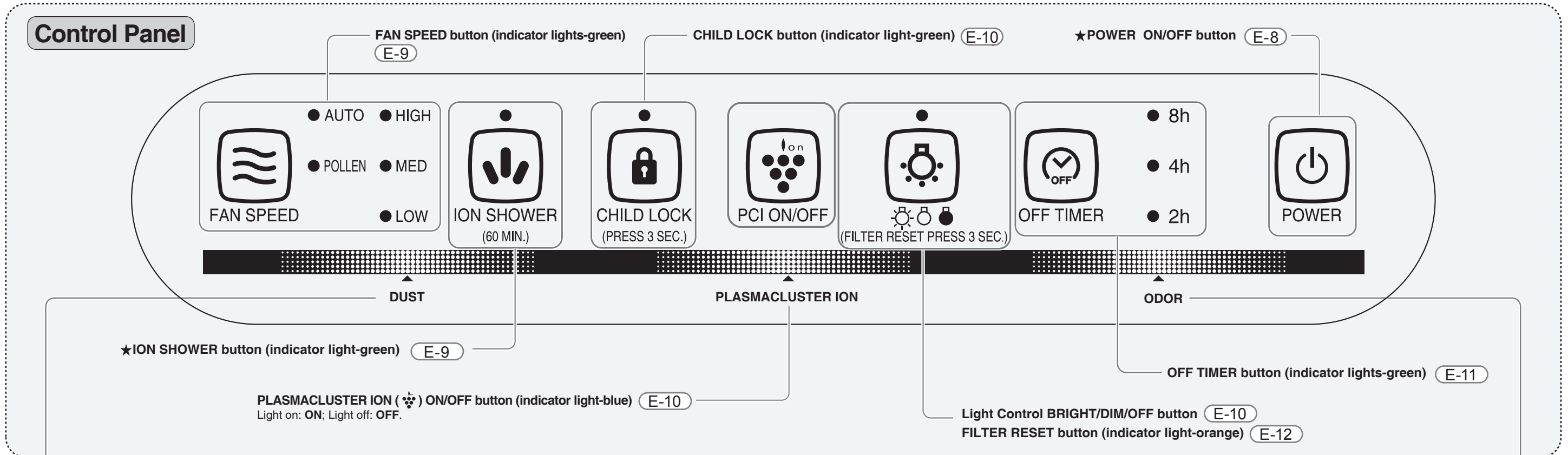

House dust monitoring and odor monitoring work together to show the air pollution level in a room. However, the Dust Sensor and the Odor Sensor monitor dust pollution and odor emission respectively, so their indicator lights may not change simultaneously.

BEFORE USE

If radio or television reception is interfered with or the wave watch cannot correctly display the time, keep the product as far away from these appliances as possible. (A possible cause of electromagnetic interference)

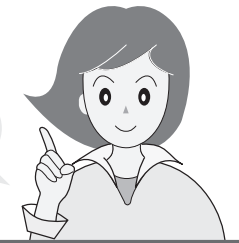

FILTER INSTALLATION

Install the filters before you insert the power plug into the power socket.

1

Remove the rear panel (pre-filter).

Rear Panel (Pre-filter)

- There are two filters in the main unit.

2

HEPA Filter Active Carbon Deodorizing Filter

- Take out the two filters from the plastic bag.

3

HEPA Filter
Active Carbon Deodorizing Filter

No difference between the front side and back side.

The figure on the left shows the installation sequence of the HEPA filter and the Active Carbon Deodorizing Filter

- The side marked with FRONT shall face outward.

4

Click

Install the rear panel (pre-filter).

PLACEMENT REQUIREMENTS

Choose a suitable place to install the main unit.

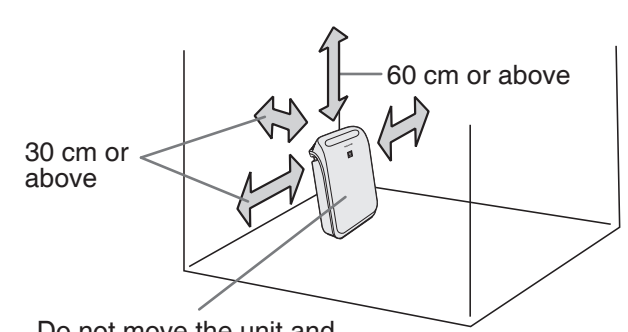

Do not move the unit and install it on a flat and stable surface.

To effectively absorb dust, the unit shall be about 30 cm away from the wall.

(Although the unit works properly near a wall without affecting its dust collection performance, the unit may stain the wall or floor. Therefore, keep the unit as far away from the wall or floor as possible.)

- **Operate the unit in a room where the ambient temperature is from 0°C to 35°C.**
Otherwise, condensation or freezing may shorten the service life of the filters or cause the unit to malfunction.
- **Keep the product away from direct sunlight.**
Otherwise, it may result in deformation, deterioration or discoloration of the main unit.
- **Do not expose the unit to direct wind from air-conditioners or heaters, or put it near a window.**
Otherwise, it may result in deformation, deterioration or discoloration of the main unit or malfunction of the sensor.
- **Put the unit on a stable and flat surface.**
Otherwise, it may cause surface depression.
- **Keep the unit far away from the curtain, wall and furniture.**
- **Clean the wall or floor around the main unit on a regular basis.**
Otherwise, it may cause dirt or damage.

BEFORE USE

HOW TO OPERATE

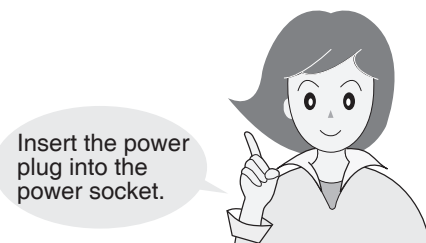
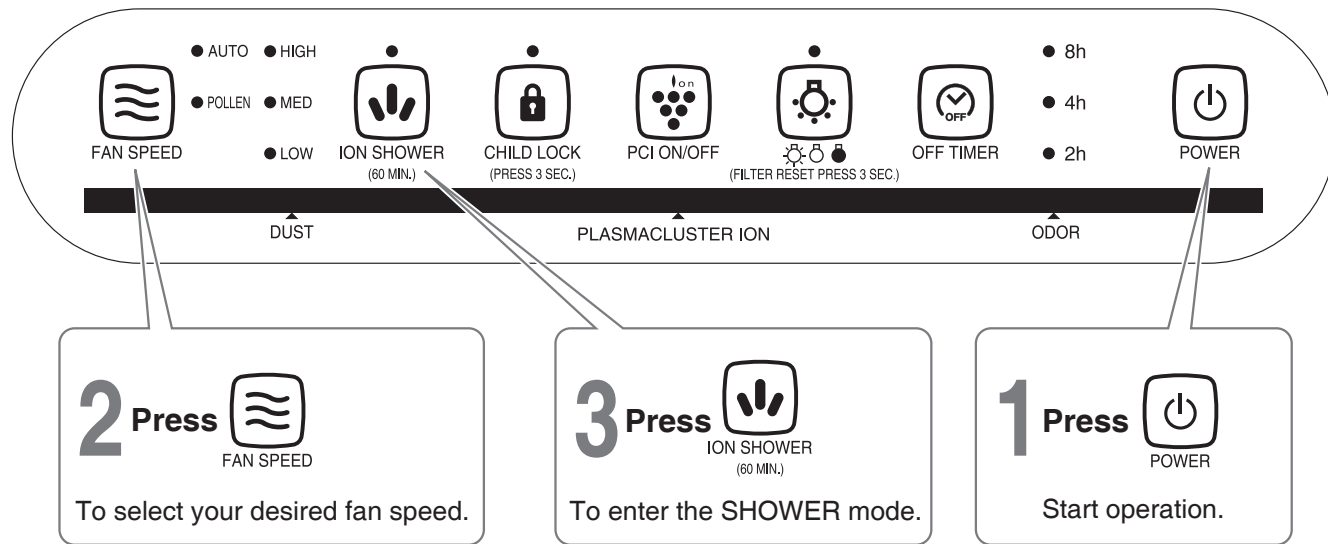

AIR PURIFICATION

START

POWER

Select your desired fan speed. **E - 9**

- Insert the power plug into the power socket. The unit begins operation with the **AUTO** fan speed, INDICATOR LIGHT **BRIGHT**, and PLASMACLUSTER ION **ON**.
- Each time you turn the unit on, it starts from the same mode as the last time.

STOP

POWER

FAN SPEED

While the unit runs in the air purification mode, you can change the fan speed. While the unit runs in the [ION SHOWER] mode, you cannot change the fan speed and the FAN SPEED indicator light is off.

Select your desired fan speed.

- AUTO ● HIGH
- POLLEN ● MED
- LOW

Each press will change the fan speed in the following sequence.

● AUTO	The unit automatically adjusts the fan speed and operation mode by detecting dust and odor according to the conditions of the room.
● POLLEN	After running at a high fan speed for 10 minutes, the unit runs alternatively between a high speed and a low speed every 20 minutes to effectively remove pollen.
● LOW	The fan works quietly at a low speed.
● MED	The fan rotates at a medium speed.
● HIGH	The fan rotates at a high speed. (The operation becomes louder.)

ION SHOWER

When the air in the room suddenly becomes dirty.

START

ION SHOWER (60 MIN.)

- When you need to remove virus and pollen after getting home.
- While or after you use a vacuum cleaner.
- After wet clothes are brought into the room.
- When you wish to remove odor as soon as possible.
- When you need to remove odor after cooking or during room cleaning.

STOP

POWER

- Press the POWER button to end the [ION SHOWER] operation.
- Press the FAN SPEED button to switch from the [ION SHOWER] mode to another mode.

NOTE When the **PLASMACLUSTER ION** is **OFF**, the unit does not release any Plasmacluster Ions, but it can remove dust and odor.

EASY-TO-USE FUNCTIONS

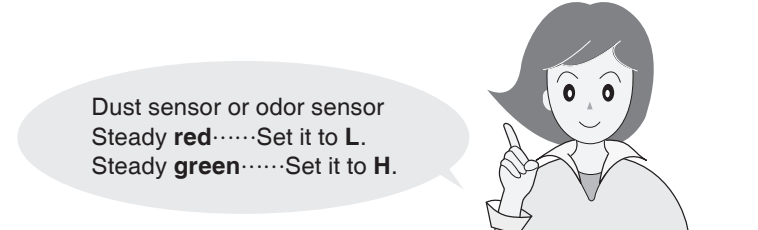

PLASMACLUSTER ION ^{Ion} ON/OFF

When you want to turn Plasmacluster Ion () on/off.

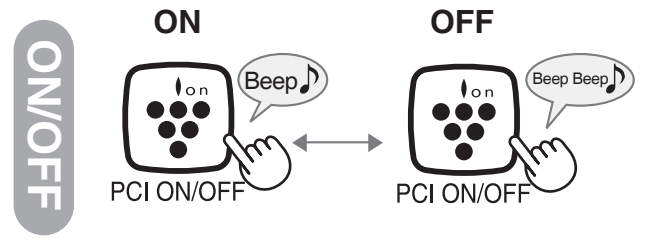

CHILD LOCK

When you want to prevent children from misoperation.

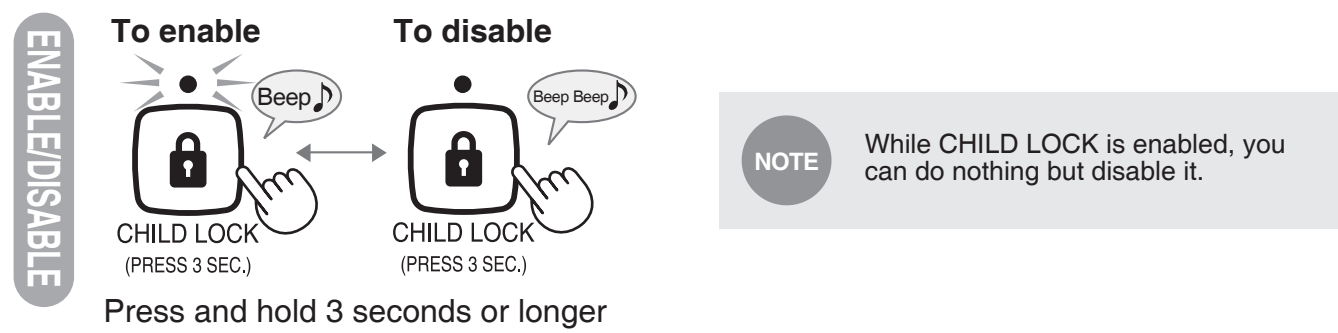

INDICATOR LIGHT BRIGHT/DIM/OFF

When you want to dim out control panel sensors or Plasmacluster ION indicator lights.

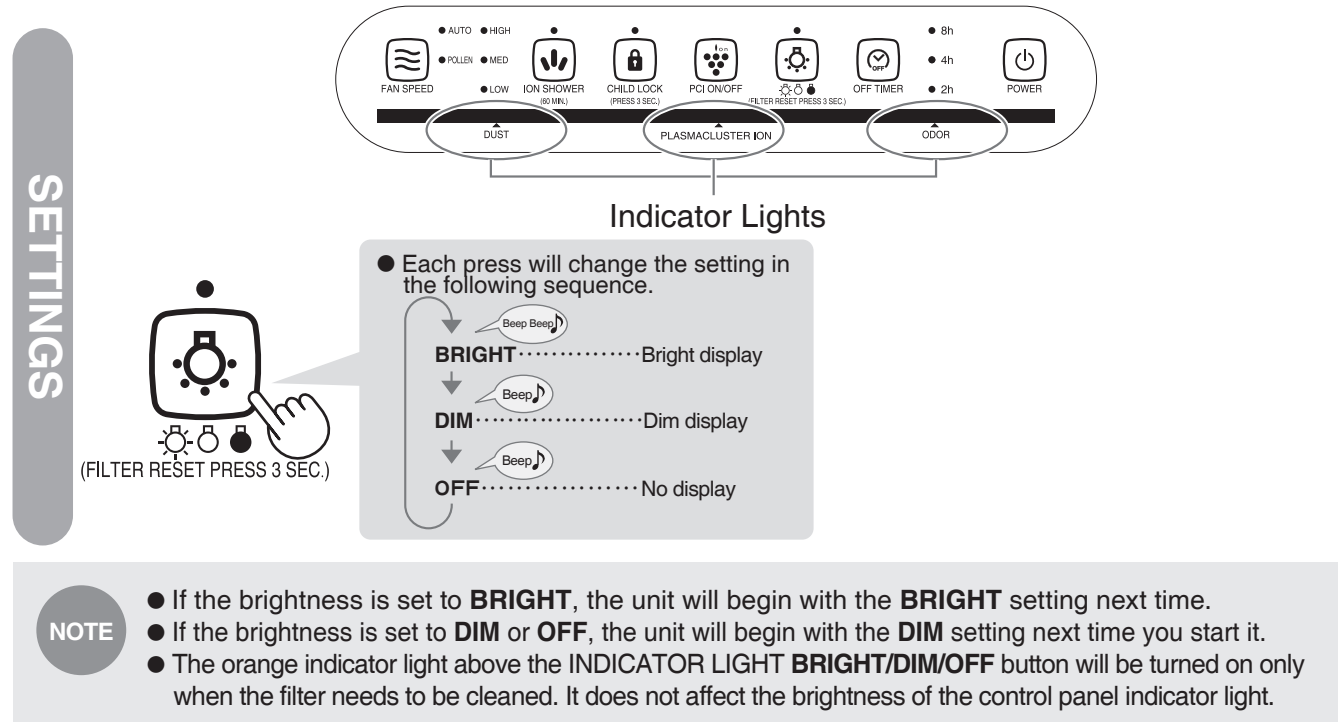

ADJUSTMENT OF SENSOR SENSITIVITY

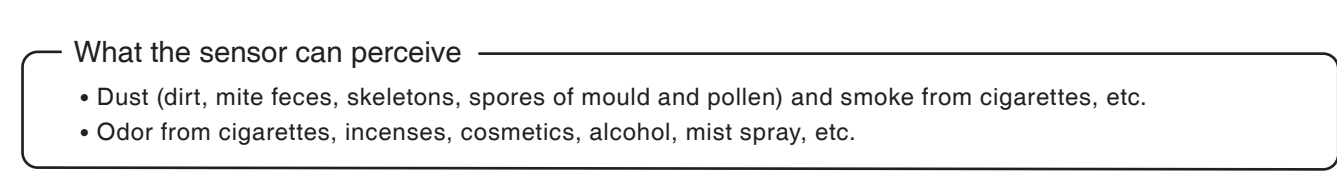
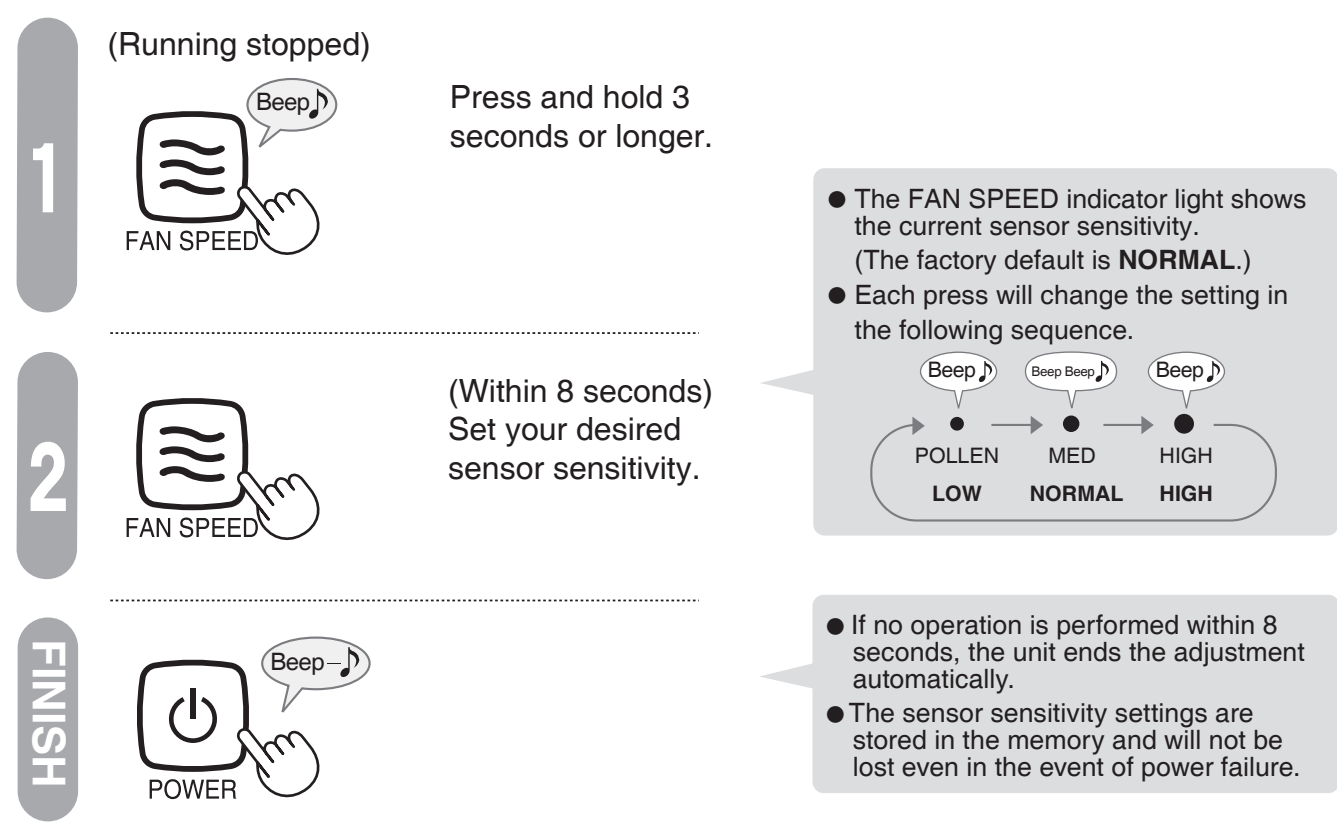

EASY-TO-USE FUNCTIONS

CARE AND MAINTENANCE



Before maintenance, be sure to shut down the unit and remove its power plug.
[Otherwise, electric shock or injury may be caused.]

To keep the unit clean and maintain its long lifetime, we recommend regular care and maintenance.



REAR PANEL (PRE-FILTER) Once a month

The indicator light is lit when it is time to maintain the rear panel (pre-filter).



● The indicator light will be lit in one month if the unit works 24 hours a day.

(FILTER RESET PRESS 3 SEC.)

1 Service the **rear panel (pre-filter)**.

ROUTINE MAINTENANCE

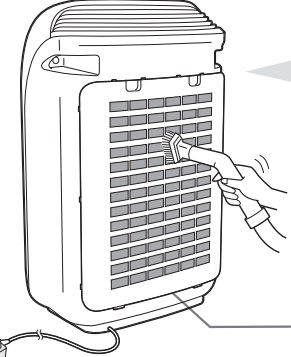

● Service the filter while it is mounted.

Use a vacuum cleaner **to remove the dust**.

NOTE Be careful not to apply too much force to the filter.

Rear Panel (Pre-Filter)

ON-DEMAND MAINTENANCE

Rear Panel (Pre-Filter)

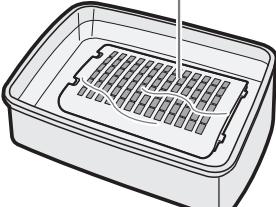

- Immerse the pre filter into a solution of kitchen-purpose synthetic detergents for 10 minutes.
- Rinse the detergent off the pre filter with clean water.
- Dry the pre filter in the shade.

2 After maintenance, insert the power plug. When the unit starts to run, press and hold the **FILTER RESET button for 3 seconds or longer** until the indicator light is off.

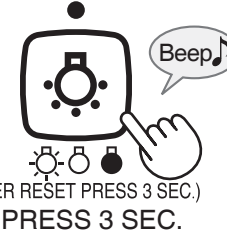

(FILTER RESET PRESS 3 SEC.)
PRESS 3 SEC.

After maintenance, press and hold the **FILTER RESET** button for 3 seconds or longer to reset the operation time even if the indicator light is not lit.

MAIN UNIT When you worry about dirt

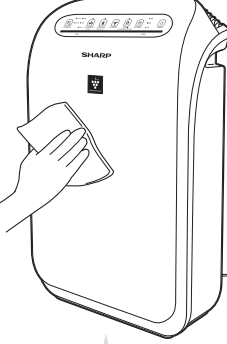







Never wash the main unit with water.

Remove the power plug, and then **wipe** the main unit with a soft cloth.

Unplug

If there are stubborn stains, wipe them off with a cloth moistened with water or warm water (below 40°C).

Do not use the following articles:
(Otherwise, surface scratch and internal liquid leakage may cause malfunction.)

					
Thinner	Volatile oil	Petrol and alcohol	Oven detergent	Decontaminant	Bleach
			Household-purpose synthetic detergent	(alkaline)	Spraying detergent
					Metal cleaning ball

HEPA FILTER, ACTIVE CARBON DEODORIZING FILTER When odor comes out from the air outlet or it is difficult to remove odor

Clean both the HEPA filter and the Active Carbon Deodorizing Filter.

HEPA Filter

Never wash the filter with water.
(Otherwise, the performance of the filter may be degraded.)

Gently absorb the dust

Clean carefully

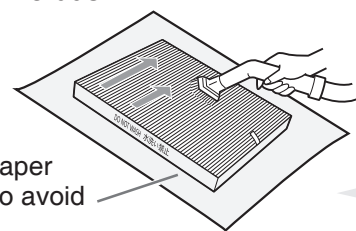

Put a piece of paper under the filter to avoid staining the surrounding area.

- Only clean the side marked with **FRONT** on the frame. Do not clean the side marked with **BACK** on the frame of the filter. (Otherwise, the performance of the filter may be degraded.)
- Remove the smelling dust on the filter.
- Do not apply too much force because the filter may be damaged easily.

Active Carbon Deodorizing Filter

Never wash the filter with water.
(Otherwise, the filter may not work any more.)

Absorb the dust gently



Put a piece of paper under the filter to avoid staining the surrounding area.

- Clean both sides of the filter. Please be noted that too much force may break the filter.
- Remove the smelling dust on the filter.

NOTE Never expose the filter to direct sunlight. (Otherwise, the filter may not work any more.)

CARE AND MAINTENANCE

ADDITIONAL INFORMATION

FLITER PERFORMANCE

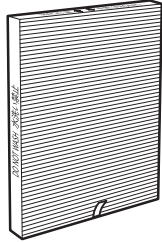
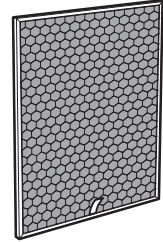
	HEPA Filter	Active Carbon Deodorizing Filter
Removable Substances	 <ul style="list-style-type: none"> • Pollen or allergen substances (mite feces and skeletons) • Virus • Mould • Dust and dirt • Smoke from cigarettes (particles) • Hair of pets 	 <ul style="list-style-type: none"> • Smell of cigarettes (odor) • Toilet odor • Odor of household garbage • Odor of pets • Formaldehyde
Irremovable Substances	<ul style="list-style-type: none"> • Harmful gas components (carbon monoxide from cigarettes, etc.) • Continuously generated odor 	

TIPS FOR EFFECTIVE OPERATION

- The air purifier is designed to remove dust or odor in a room. If there are strong smells of fragrance, sesame oil, cigarette or roast, the odor will attach to the surface of the filter, and this may occur within several weeks or months. In such cases, clean the **Active Carbon Deodorizing Filter** and the **HEPA filter**. If odor persists, replace the filters.
- When the unit is used in the presence of strong smells, it is recommended to ventilate the room frequently.
- It takes more time to remove odor than dust.
- **Do not use cosmetics* containing silicone around the main unit.**
If silicone attaches to the inside of the unit, Plasmacluster Ions cannot be generated.
*Hair care products (hair care solution and hair mousse), cosmetics, antiperspirant, antistatic agent, water spray, polishing agent, glass cleaning fluid, chemical cloth, wax, etc.

FILTER REPLACEMENT

Before maintenance, be sure to shut down the unit and remove its power plug.
[Otherwise, electric shock or injury may be caused.]

HEPA FILTER, ACTIVE CARBON DEODORIZING FILTER

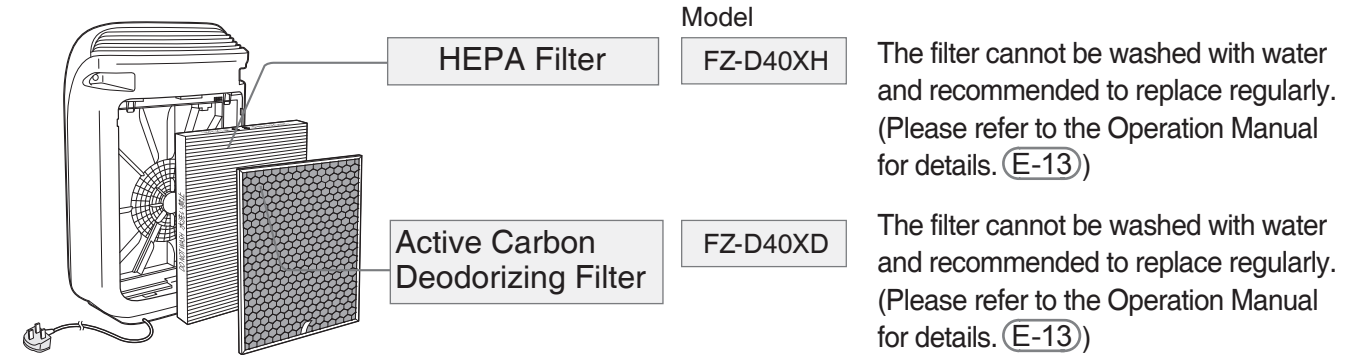

NOTE

- Put a piece of paper under the filter during replacement to avoid staining the surrounding area.
- Dispose of replaced filters in compliance with the local garbage classification guidelines.
- Depend on different working environments, the filters is recommended to replace within several weeks or months because of smells.
- As consumables, filters are charged even in the warranty period.

Replacement and Maintenance Cycle

Filter Name	Maintenance Cycle	Max Service Life	Replacement Filter Model
HEPA Filter	When odor comes out from the air outlet	5 years	FZ-D40XH
Active Carbon Deodorizing Filter※	When odor comes out from the air outlet	5 years	FZ-D40XD

※According to the Japan Electrical Manufacturer's Association JEM1467, if the volume of dust is equivalent to 5 cigarettes absorbed per day, the deodorizing capacity of filter is reduced by 50%.
If the volume of dust is equivalent to 10 cigarettes absorbed per day, the filter is recommended to replace every 2.5 years.

TROUBLESHOOTING



	Problem	Solution	Reference Page												
ODOR	The odor or smoke is hard to remove.	<ul style="list-style-type: none"> ● Is the filter still wrapped in the plastic bag? ⇒ Take out the filter from the plastic bag. ● Is the wind blowing become weaker? ⇒ Clean the areas with ★ in the following table: <table border="1" style="margin-left: 20px;"> <thead> <tr> <th colspan="4">Cleaning Areas</th> </tr> <tr> <th>Main Unit</th> <th>Rear Panel</th> <th>Active Carbon Deodorizing Filter</th> <th>HEPA Filter</th> </tr> </thead> <tbody> <tr> <td></td> <td style="text-align: center;">★</td> <td style="text-align: center;">★</td> <td style="text-align: center;">★</td> </tr> </tbody> </table>	Cleaning Areas				Main Unit	Rear Panel	Active Carbon Deodorizing Filter	HEPA Filter		★	★	★	E - 6 E - 12~13
	Cleaning Areas														
Main Unit	Rear Panel	Active Carbon Deodorizing Filter	HEPA Filter												
	★	★	★												
	Odor comes out from the air outlet.	<ul style="list-style-type: none"> ● Is the unit used in a room with strong smells? If the unit is used in the presence of strong smells such as cigarette and roast, the filters may smell . ⇒ It is recommended to frequently ventilate the room where the air purifier is used. ● Clean the areas with ★ in the following table, if odor persists, replace the filters. <table border="1" style="margin-left: 20px;"> <thead> <tr> <th colspan="4">Cleaning Areas</th> </tr> <tr> <th>Main Unit</th> <th>Rear Panel</th> <th>Active Carbon Deodorizing Filter</th> <th>HEPA Filter</th> </tr> </thead> <tbody> <tr> <td></td> <td></td> <td style="text-align: center;">★</td> <td style="text-align: center;">★</td> </tr> </tbody> </table> <ul style="list-style-type: none"> ● The Plasmacluster Ion generator could generate a tiny amount of ozone together with Plasmacluster Ions. Therefore, odor may come out from the air outlet, which does not affect your health. 	Cleaning Areas				Main Unit	Rear Panel	Active Carbon Deodorizing Filter	HEPA Filter			★	★	— E - 12~13 —
Cleaning Areas															
Main Unit	Rear Panel	Active Carbon Deodorizing Filter	HEPA Filter												
		★	★												
INDICATOR LIGHT	The FILTER RESET indicator light is lit.	<ul style="list-style-type: none"> ● Clean the areas with ★ in the following table: <table border="1" style="margin-left: 20px;"> <thead> <tr> <th colspan="4">Cleaning Areas</th> </tr> <tr> <th>Main Unit</th> <th>Rear Panel</th> <th>Active Carbon Deodorizing Filter</th> <th>HEPA Filter</th> </tr> </thead> <tbody> <tr> <td></td> <td style="text-align: center;">★</td> <td></td> <td></td> </tr> </tbody> </table>	Cleaning Areas				Main Unit	Rear Panel	Active Carbon Deodorizing Filter	HEPA Filter		★			E - 12
	Cleaning Areas														
Main Unit	Rear Panel	Active Carbon Deodorizing Filter	HEPA Filter												
	★														
	The FILTER RESET indicator light does not turn off.	<ul style="list-style-type: none"> ● After maintenance, press and hold the FILTER RESET (BRIGHT/DIM/OFF) button for 3 seconds or longer. 	E - 12												
SOUND	A continuous clatter is heard.	<ul style="list-style-type: none"> ● The sound is heard when Plasmacluster Ions are generated. The sound volume varies with the working environment and operation mode. Sometimes, the sound cannot be heard but the effect of Plasmacluster Ions is completely the same. 	—												

	Problem	Solution	Reference Page
DUST/ODOR SENSOR	The Indicator Light does not change.	<ul style="list-style-type: none"> ● When start the operation, the sensor may become unstable in sensitivity and the color of the odor sensor may not change. ⇒ After the unit has been running for several minutes, the sensor sensitivity will become stable. ● If the indicator light of sensor turns green and persists, the air is clean. It may be difficult to sense odor. When you blow cigarette smoke to the sensor or slap a towel near it, if the colors of the odor sensor and dust sensor have changed, this means that the sensor is working properly. ● If you switch the unit on when the room has a strong smell, the sensitivity of the odor sensor may be deteriorated. ⇒ Set Fan Speed to MED and run the unit for several hours or whole day. ● Sometimes, the sensor sensitivity does not match the room conditions. ⇒ Shut down the unit, and adjust the sensitivity. 	E - 11 — — E - 11
	The Indicator Light never turns green.	<ul style="list-style-type: none"> ● The door or windows are opened frequently. In a room with poor air tightness, it takes some time to purify the air (until the sensor turns green). 	—
	The Indicator Light switches its state frequently.	<ul style="list-style-type: none"> ● The door opened and closed constantly, wind and sharp temperature changes may cause reactions. 	—
	The Indicator Light is dazzling.	<ul style="list-style-type: none"> ● Adjust the brightness of indicator lights. Press the Light Control (BRIGHT/DIM/OFF) button. 	E - 10

SPECIFICATIONS

Model	FU-D40A		
Power Supply	220-240V 50/60Hz		
Applicable Floor Area (m ²)	31		
Fan Speed Mode	LOW (L)	MEDUIM (M)	HIGH(H)
Air Flow Volume (m ³ /hour)	80	200	250
Rated Power Consumption (W)	4.6	14.2	29.0
Noise Level (dBA)	27.3	41.1	46.5
Dimensions (mm)	357(W) × 201(D) × 576(H)		
Weight (kg)	~ 5.5		
Power Cord Length (m)	1.8		

Filters

Filter Name	Filter Model
HEPA Filter	FZ-D40XH
Active Carbon Deodorizing Filter	FZ-D40XD

Note: The service life of **HEPA Filter** is up to 5 years.

The service life of **Active Carbon Deodorizing Filter** is up to 5 years.*

For details on how to maintain the filters, see the Operation Manual. (E-12, 13, 15)

※ The max service life of **Active Carbon Deodorizing Filter** is calculated according to the Japan Electrical Manufacturer's Association JEM1467.

If the volume of dust is equivalent to 5 cigarettes absorbed per day, the deodorizing capacity of filter is reduced by 50%. If the volume of dust is equivalent to 10 cigarettes absorbed per day, the filter is recommended to replace every 2.5 years.

Depend on the different working environments, the filter is recommended to replace within several weeks or months because of smells.

SHARP®

空氣清新機

使用說明書

型號

FU-D40A

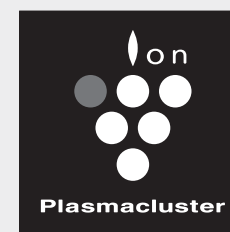

High - Density 7000

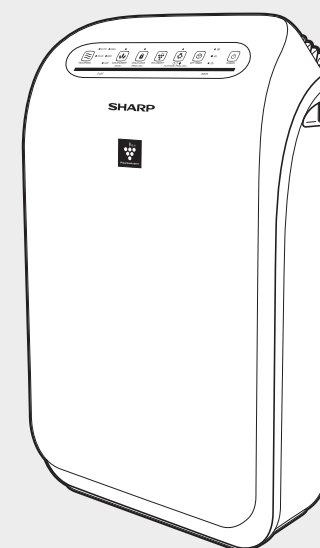

衷心感謝您購買聲寶空氣清新機。
操作之前，請仔細閱讀說明書，以便正確地使用空氣清新機。請將使用說明書保存好以備參考。



Device of this mark is a trademark of Sharp Corporation.
Plasmacluster is a registered trademark or a trademark of Sharp Corporation.

目錄

頁數

請務必閱讀

- 重要安全事項
- 各部分名稱
- 準備工作
 - 過濾網安裝
 - 放置要求

C-2

C-4

C-6

使用方法

- 操作方法
 - 空氣淨化
 - 強力PCI除菌
- 方便的功能
 - PCI(❖) 開 / 關
 - 兒童安全鎖
 - 指示燈亮度調校
 - 感測器靈敏度調整
 - 定時關機

C-8

C-10

保養

- 背板(前置過濾網)
 - 正常情況下的保養
 - 嚴重髒污及有異味時的保養
- 主機
- HEPA集塵過濾網、
活性碳除臭過濾網

C-12

請予以瞭解的事項

- 過濾網性能
- 為了有效使用空氣清新機

C-14

過濾網更換指南

- HEPA集塵過濾網、
活性碳除臭過濾網

C-15

檢查事項

故障時的檢查事項

C-16

規格

規格

C-18

本產品專為家庭用戶設計，而非為商業用戶設計



重要安全事項

請務必遵守!



- 除非得到監護人或負責其安全人士的適當監督或指導，否則，此機器不適合身體官能或心智能力退化者，或缺乏操作經驗和知識的人士(包括兒童)使用。
- 兒童應受到適當監管以確保不會以此機器作玩具。

為防止對用戶或對他人造成危害及財產的損害，請遵守以下事項：

■ 以下圖表顯示錯誤使用或操作可能會產生的後果。



- | |
|---|
|  警告 表示有可能會引致死亡或重傷 |
|  注意 表示有可能會引致受傷或財產受到損害 |

■ 請遵守以下圖案所表示的內容。

- | |
|---|
|  表示不能違反的禁止行為 |
|  表示必須遵守的強制行為 |

警告 為防止火災、觸電、受傷

電源插頭、電源線

-  ● 不可使用額定電壓220-240V (50/60Hz) 之外的電源。
(否則可能是引起火災、觸電的原因)
- 請勿使電源線破損或對其進行任意加工、強行彎曲、拉拔、扭轉、捆紮。
(電源線破損是引起火災、觸電的原因)
- 請勿承載重物或對其加壓。
(電源線破損是引起火災、觸電的原因)
- 電源線或電源插頭破損時或插入電源插座鬆掉時，請勿使用。
(否則可能是引起火災、觸電、短路的原因)
- 請勿使用潮濕的手去插拔電源線。
(否則可能是引起觸電的原因)
- 請勿擅自更換電源線，在因損壞，確需更換時，請與聲寶維修服務中心聯繫。
-  ● 對電源插頭或插座上的積塵應定期清掃。
(積塵過多、於潮濕天氣使用時會引起絕緣不良，它是引起火災、觸電的原因)

保養時

- 在進行保養、清洗或移動時，請務必停止主機操作，拔下電源插頭。
(否則可能是引起觸電和受傷的原因)

異常發生時(有燒焦異味等)

-  ● 停止運行，拔下電源插頭。
(否則可能是引起冒煙、著火、觸電、受傷的原因)
- 應馬上停止運行，拔下電源插頭，與聲寶的維修服務中心聯繫。

使用

-  ● 請勿將手指、棍棒等插入(伸入)吹出口、吸入口。
(否則可能是引起觸電、故障的原因)
- 請勿擅自對機器進行改造、分解、修理。
(否則可能是引起火災、觸電、受傷的原因) 需要修理時，請與聲寶的維修服務中心聯繫。
- 請避免將茶水等打翻在機器上。請避免水直接進入機器內部。
(機器內部若有水進入，是引起觸電、短路、著火的原因)
- 請避免在幼童所能觸及的範圍內使用。
(否則可能是引起觸電、受傷的原因)

注意

為防止漏電、受傷和保護家庭財產不受到損害

電源插頭、電源線

- 拔下電源插頭時，請務必手握插頭。
(否則可能是引起火災、觸電、短路的原因)
- 長時間不使用時，請務必將電源插頭從插座上拔下。
(絕緣劣化是引起觸電、火災的原因)

使用

-  ● 請勿放在可燃性物體、點燃的香煙等附近。
(否則可能是引起著火的原因)
- 請勿使用汽油、化學藥劑等溶劑擦拭。請勿噴灑殺蟲劑。
(否則可能是引起表面裂紋、觸電、火災的原因)
- 在使用室內殺蟲劑時，請勿開啟空氣清新機。機器內部若有藥劑成分積聚，藥劑會隨著機器的開啟從吹出口放出，對健康無益。因此在使用殺蟲劑以後，必須保持房間空氣流通。
- 請勿坐在或靠在空氣清新機上。
(翻倒可能會引起受傷或故障)
- 請勿用於美術品、學術資料等的保存。請勿用於業務等特殊用途。
(否則可能是引起保存品品質降低的原因)
- 請勿放在不穩定的地方。請勿在傾斜、不穩定、高的地方放置。
- 請不要在浴室等濕氣多、有水的場所使用。
(否則可能是引起火災、觸電、故障的原因)

-  ● 移動時請務必停止運行，並抓緊主機後面兩側的把手搬運。



- 與燃燒器具一起使用時，請打開窗戶保持房間空氣流通。
本產品並不是除去一氧化碳等有害物質的機器。
(在空氣不流通的情況下，可能會因為氧氣不足而引致窒息。)

各部分名稱

只要按下帶★記號的按鍵，機器即開始運行。

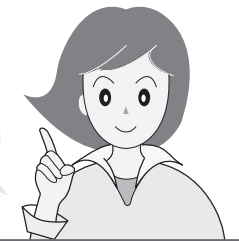

主機、操作面板

操作面板

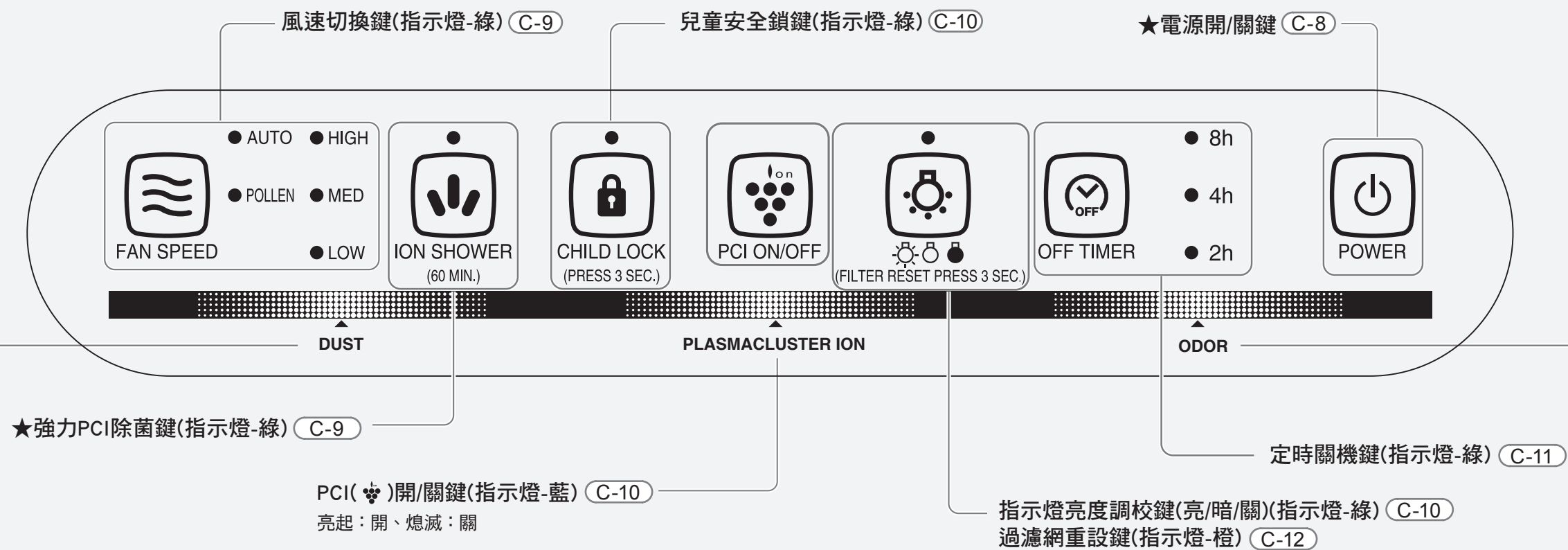

塵埃監測



塵埃監測器

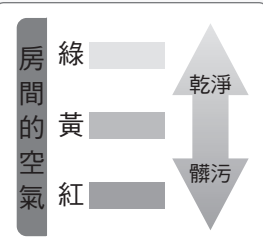

後面

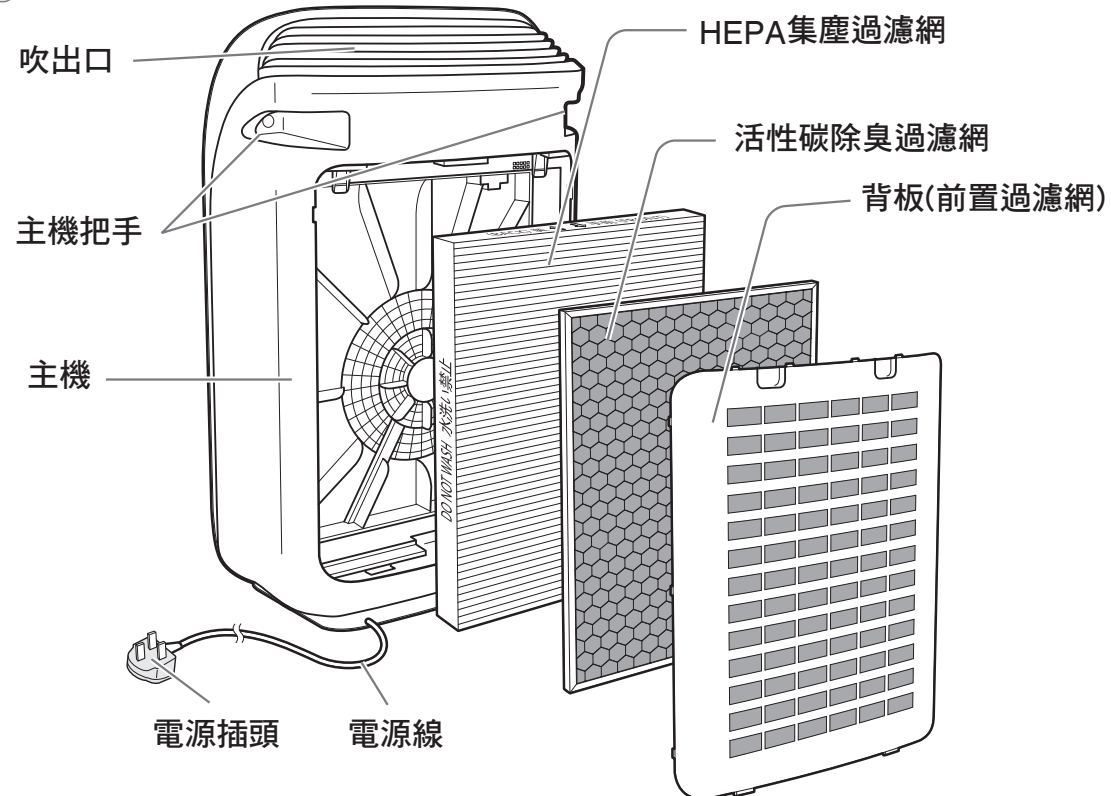

前面

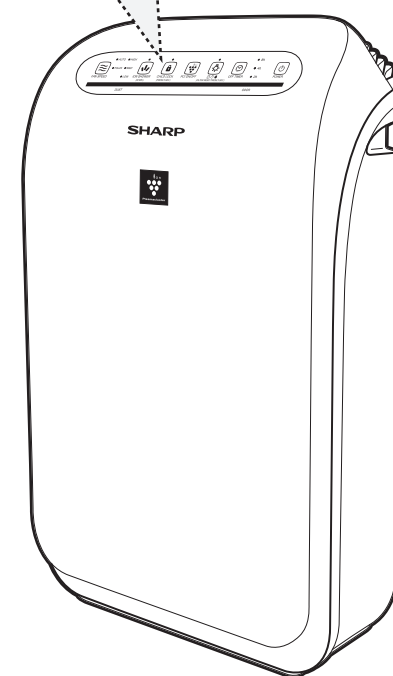

異味監測



異味監測器

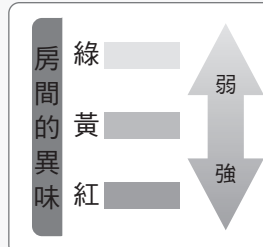

塵埃和異味監測器提示房間內的空氣污染狀況(灰塵和異味)。他們是通過各自的感測器來進行監測的，因此指示燈的顏色可能不會同時發生變化。

準備工作

電視機/收音機若有干擾或電波手錶無法正確顯示時間時，請盡可能遠離這些電器。(電磁波干擾的原因)

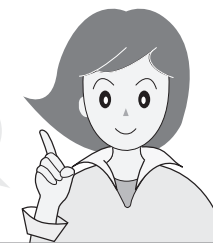

過濾網安裝

請在電源插頭插入插座之前進行。

1

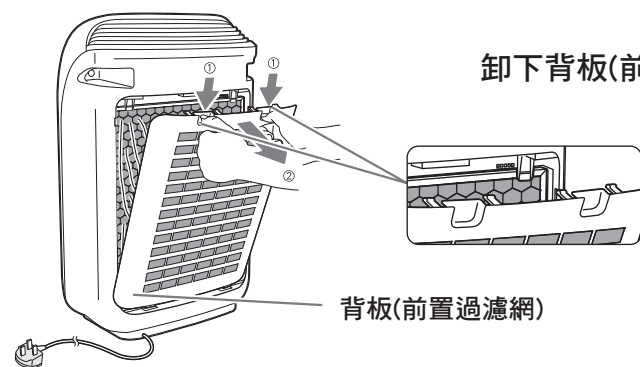

卸下背板(前置過濾網)

主機中放有兩種過濾網。

背板(前置過濾網)

2

HEPA集塵過濾網

活性炭除臭過濾網

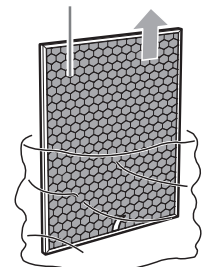
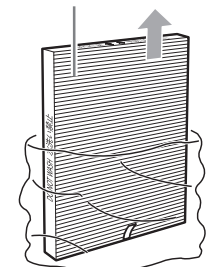

將過濾網(兩種)從塑料袋內取出來。

3

HEPA集塵過濾網

活性炭除臭過濾網

無正反面之分

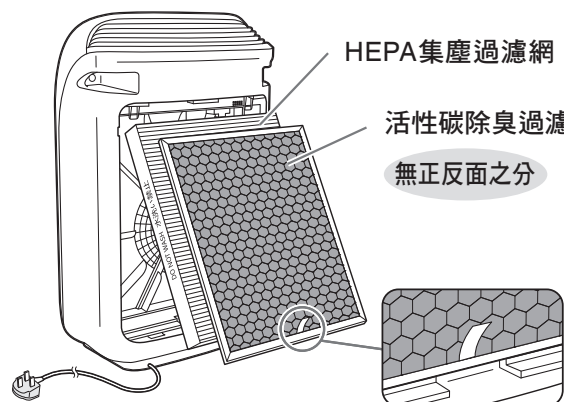

HEPA集塵過濾網外框上標注「手前」的一面朝外安裝。

左圖顯示HEPA集塵過濾網及活性炭除臭過濾網安裝順序

4

咔嗒

裝回背板(前置過濾網)

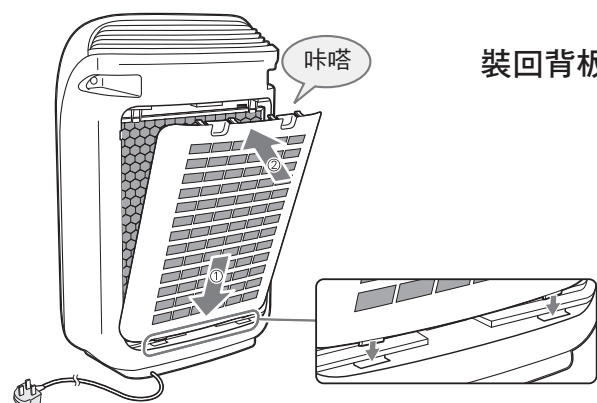

放置要求

主機請放在最合適的地方。

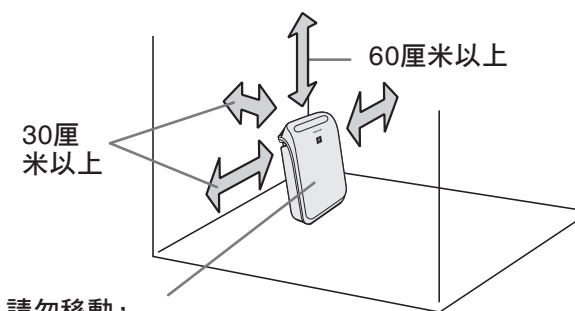

請勿移動，
放在平坦穩固的地方。

為了有效地吸入灰塵，把主機放在離開牆壁約30厘米(主機後面和牆壁之間的距離)的地方是最合適的。

(主機放在貼近牆壁的地方，並不會影響集塵能力，但有可能會弄髒周圍的牆壁或地面，因此請盡可能保持適當的距離。)

- 請於0~35°C的房間內使用。
結露或凍結可能是影響過濾網壽命或引起故障的原因。
- 請盡量避免陽光直射。
否則可能是引起主機變形、變質、變色的原因。
- 請勿放在空調、發熱器或窗戶附近。
否則可能是引起主機變形、變質、變色的原因。
- 請放在穩固平坦的地方。
否則可能會引致地面凹陷損傷。
- 遠離窗簾、牆壁、家具等。
- 對主機周圍的牆壁或地面要經常清掃。
否則可能是引起髒污或損傷的原因。

準備工作

操作方法

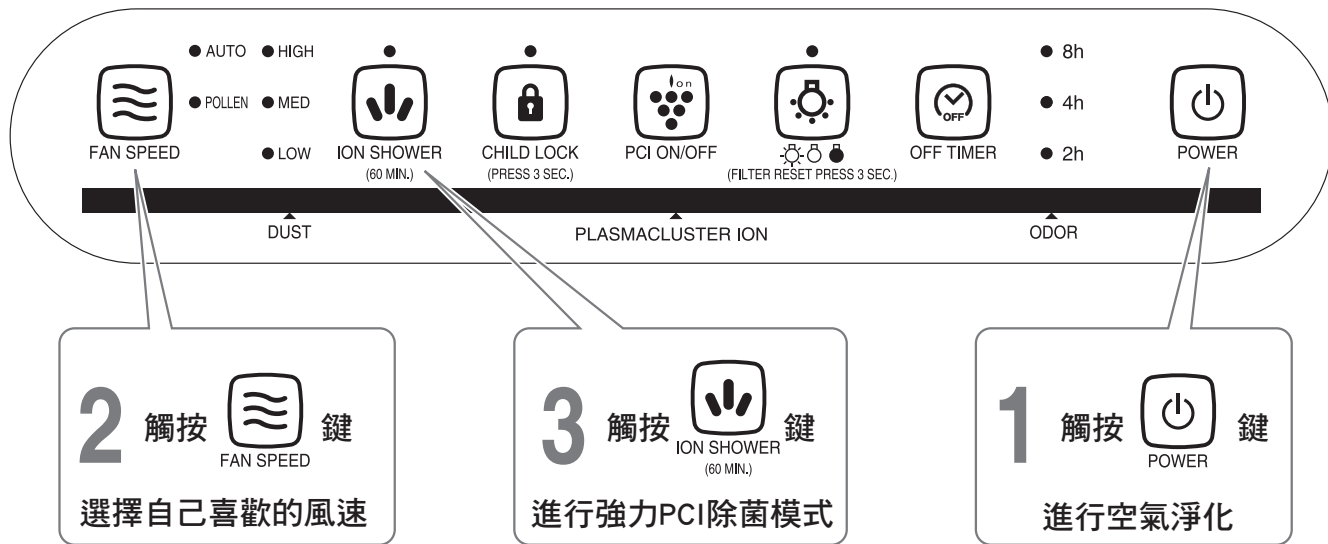

風速切換

在進行空氣淨化模式時，可以改變風速大小。而在強力PCI除菌模式運行時，將無法改變風速大小，而風速切換的指示燈將會熄滅。

選擇自己喜歡的風速

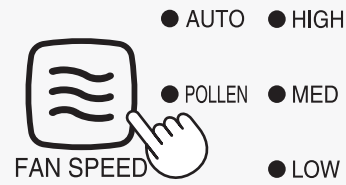

每按一下，即按如下的順序改變。

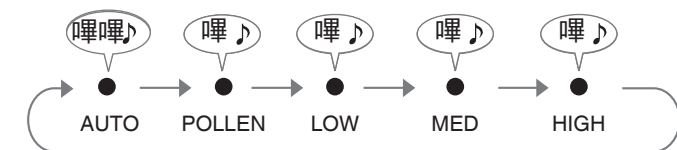

● AUTO	根據房間的狀態，通過灰塵、異味的檢測，自動對風速進行調整和運行。
● POLLEN	在10分鐘高風速運行以後，接著將每20分鐘交替進行較強和較弱風速運行，有效去除花粉。(較弱風速：比中風速稍弱)
● LOW	風速持續在 低風速 下較安靜地運行。
● MED	風速持續在 中風速 下運行。
● HIGH	風速持續在 高風速 下運行。(運行聲將變大)

強力PCI除菌

室內的空氣突然變髒污時。

運行



- 室外帶回家的病毒、花粉
- 使用吸塵器時或使用之後
- 室內晾曬衣服的陰乾氣味
- 室內異味
- 烹調後或房間清潔時的異味

終止

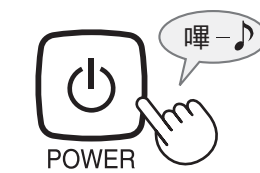

- 當希望終止強力PCI除菌模式時，按「POWER」(開/關)鍵。
- 當希望停止強力PCI除菌模式及轉換至其他模式時，請按「FAN SPEED」(風速切換)鍵進行轉換。

注意 「PLASMACLUSTER ION」^{ion} 設定在「OFF」(關)的狀態時，將沒有PCI產生，但可以去除灰塵和異味。

將電源插頭插入插座。

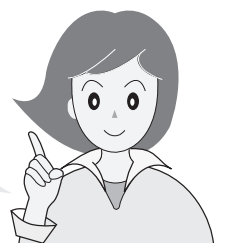

空氣淨化

運行

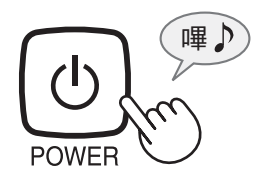

選擇自己喜歡的風速 (C-9)

- 最初開始運行時，將自動設定在風速「AUTO」(自動)、指示燈亮、PCI「ON」的狀態。
- 從第二次開始，將與前一次相同的模式下運行。

停止

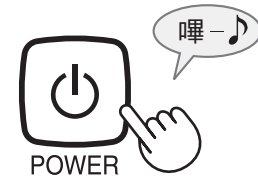

方便的功能

塵埃監測器或異味監測器
紅色不變時……請調整到「L」(低)
綠色不變時……請調整到「H」(高)

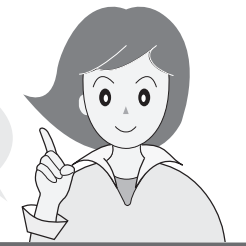

PCI()開/關

設定PCI()開/關時。

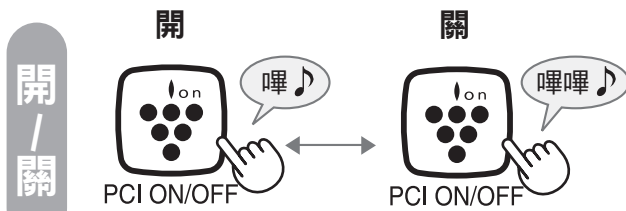

兒童安全鎖

希望防止兒童亂摸或錯誤轉換模式時。

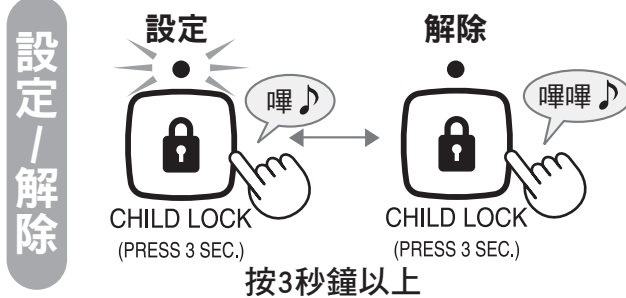

注意 在兒童安全鎖設定狀態下，除「CHILD LOCK」(兒童安全鎖)鍵之外的操作一律無效。

指示燈亮度調校

在感到監測器或PCI指示燈刺眼時。

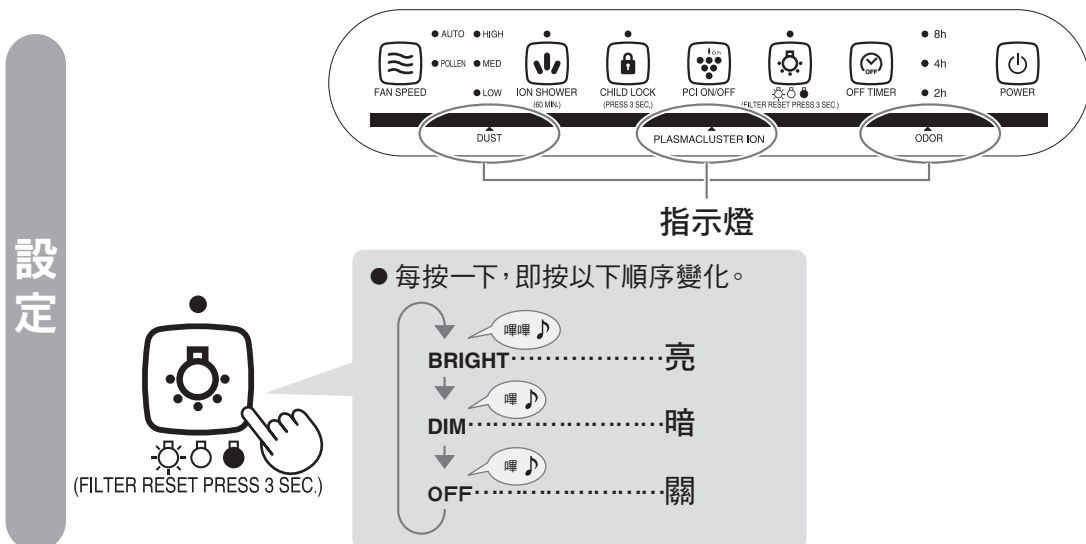

注意

- 明亮度設定在亮的狀態，運行停止後又開始啟動機器時，明亮度將在亮的狀態下開始運行。
- 明亮度設定在暗或關的狀態，運行停止後又開始啟動機器時，明亮度將在暗的狀態下開始運行。
- 指示燈的亮/暗/關鍵上方的橙色指示燈在過濾網需要清洗時才會亮起，對操作面板的指示燈明亮度沒有作用。

感測器靈敏度調整

(在操作停止時)

按3秒鐘以上。



(8秒鐘以內)
設定自己喜歡的
感測器靈敏度。

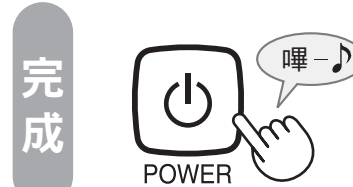

- 風速切換指示燈將表示當前設定的感測器靈敏度。(出廠時，設定在「M」(標準)的狀態)
- 每按一次，即按以下順序變化。

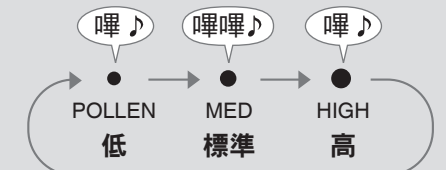

- 8秒鐘內沒有操作的情況下，將作自動調整結束處理。
- 感測器靈敏度的設定，即使在斷電的情況下也會記憶。

感測器可感測的物質

- 室內的塵埃(灰塵、蟻蟲的排泄物、屍骸、黴菌的孢子、花粉)、香煙的煙塵等。
- 香煙的異味、化妝品、酒精、噴霧類等的異味。

定時關機

設定自動關閉主機的時間。

(運行中)

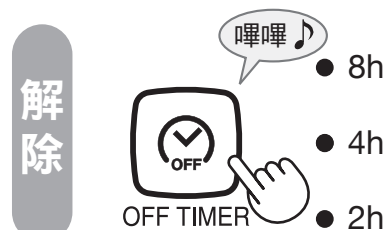
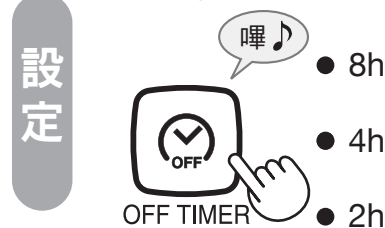

- 每按一次，即按如下順序變化。

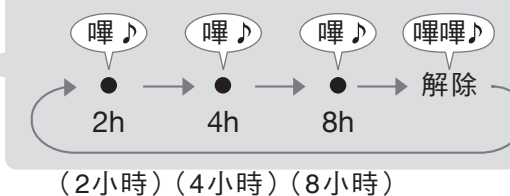

方便的功能

保養

 保養時，請務必停止運行，並拔下電源插頭。
【否則可能是引起觸電或受傷的原因】

為了能長久地使用，請定期進行保養。

背板(前置過濾網) 1個月1次

當指示燈亮起時，請清潔背板(前置過濾網)。

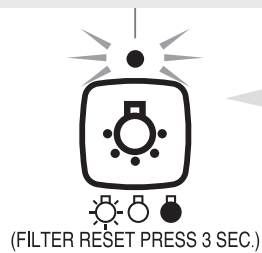

- 在1天24小時操作的情況下，約在1個月以後(720小時)指示燈將會亮起。

1

對背板(前置過濾網)進行清潔。

正常情況下的保養

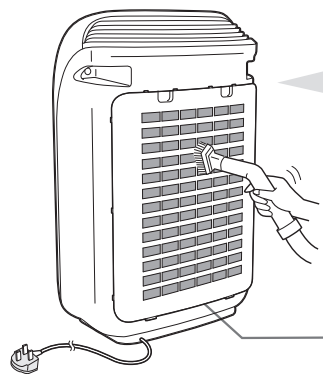

- 在安裝狀態下，進行清潔。

以吸塵器吸取和清掃灰塵。

背板(前置過濾網)

注意

若用力過度，過濾網部分可能會破損，請予以注意。

嚴重髒污及有異味時的保養



- 放在清潔劑的溶液中浸洗約10分鐘。
- 請充分清洗乾淨，注意不要有清潔劑液殘留。
- 自然晾乾。

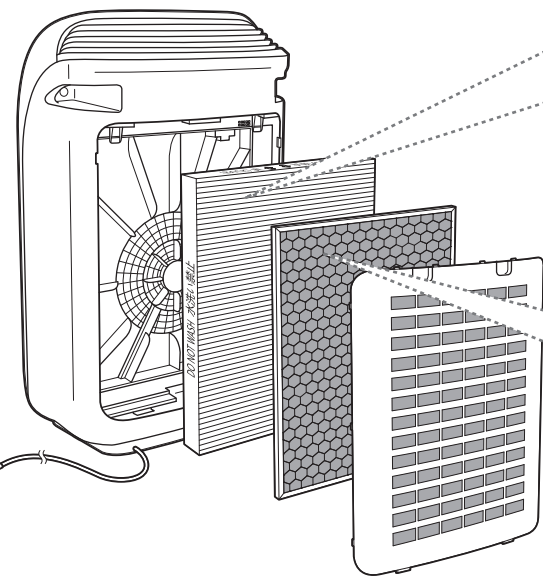

2

保養以後，插入電源插頭開始運行，持續按「FILTER RESET」(過濾網重設)鍵3秒鐘以上直至指示燈熄滅。

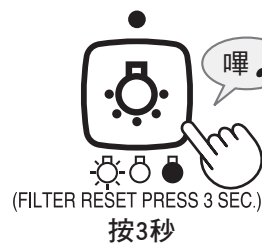

保養以後，即使「FILTER RESET」(過濾網重設)指示燈沒有亮起，因為要重設運行時間，請持續按「FILTER RESET」(過濾網重設)鍵3秒鐘以上。

主機

對髒污擔心時



請勿水洗。

請先拔下電源插頭，再用柔軟的布擦拭。

拔下

污漬嚴重時，請用含溫水(40°C以下)的濕布擦拭。

下面的物品請勿使用。
(表面劃傷、內部有液體滲漏，都是引起故障的原因)



HEPA集塵過濾網、活性炭除臭過濾網

當異味從吹出口吹出或異味較難去除時

請同時對HEPA集塵過濾網、活性炭除臭過濾網進行保養。

HEPA集塵過濾網



請絕對不要用水清洗。

(否則將損害過濾網的性能)

對過濾網的前方輕輕吸取

小心清掃

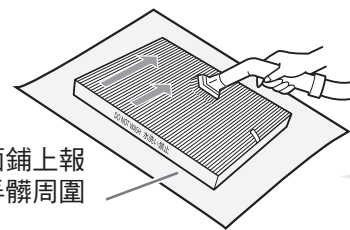

在過濾網的下面鋪上報紙，可以避免弄髒周圍環境。

- 清掃請僅對邊框上標注「手前」的一面進行。過濾網的邊框上標注「奧」的一面，請絕對不要對其進行清掃。(否則將損害過濾網的性能)
- 清除過濾網上有異味的灰塵。
- 由於過濾網比較容易破損，請注意不要用力過度。

活性炭除臭過濾網



請絕對不要用水清洗。

(否則過濾網將會失去其應有的功能)

輕輕吸取

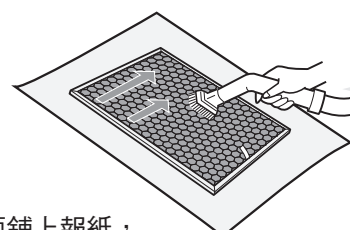

在過濾網的下面鋪上報紙，可以避免弄髒周圍環境。

- 可以對兩面進行清潔保養。對過濾網若用力過猛，可能會引起斷裂，因此在清潔保養時請務必注意。
- 清除過濾網上的灰塵。

注意

請絕對不要在太陽底下照曬。
(否則過濾網將會失去其應有的功能)

保養

請予以瞭解的事項

過濾網性能

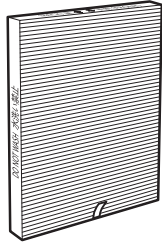
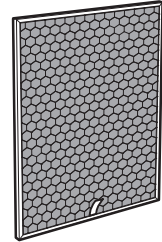
	HEPA集塵過濾網	活性炭除臭過濾網
可去除物質	 <ul style="list-style-type: none"> 花粉或致敏原物質 (蟎蟲的排泄物、屍骸) 病毒 霉菌 灰塵、塵埃 香煙的煙塵(粒子) 寵物的毛髮 	 <ul style="list-style-type: none"> 香煙的煙味(異味) 廁所的異味 生活垃圾的異味 寵物的異味 甲醛
無法去除的物質	<ul style="list-style-type: none"> 有害氣體成分 (香煙的一氧化碳等) 持續發生的異味成分 (建材異味等) 	

為了有效使用空氣清新機

- 由於空氣清新機是去除房間灰塵或異味的機器，在有芳香劑、香油、香煙或烤肉等強烈氣味的環境下使用的話，異味將會附著在過濾網的表面，有可能會發生在數周或數月內就有異味產生的情況。當發生這種情況時，請對活性炭除臭過濾網、HEPA集塵過濾網進行保養。如保養後仍無法去除異味，請更換各種過濾網。
- 在有強烈氣味的環境下使用，請保持室內空氣流通。
- 與去除灰塵相比，去除異味更花費時間。
- 在主機周圍，請勿使用含有矽酮的化妝品。*
主機內部若有矽酮附著，PCI將無法產生。
* 護髮商品(頭髮護理液、頭髮摩絲等)、化妝品、止汗劑、靜電防護劑、防水噴霧劑、拋光劑、玻璃清洗液、化學抹布、蠟等。

過濾網更換指南

 保養時，請務必停止運行，並拔下電源插頭。
【否則可能是引起觸電或受傷的原因】

HEPA集塵過濾網、活性炭除臭過濾網

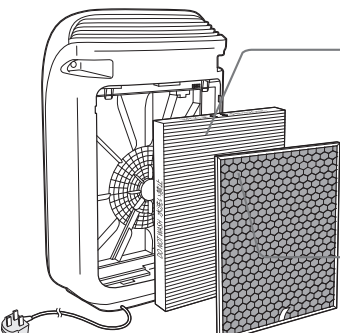

名稱	型號	說明
HEPA集塵過濾網	FZ-D40XH	不可水洗，請定期進行更換。(請根據使用說明書中過濾網安裝的相關內容進行更換。C-13)
活性炭除臭過濾網	FZ-D40XD	不可水洗，請定期進行更換。(請根據使用說明書中過濾網安裝的相關內容進行更換。C-13)

注意

- 為避免弄髒周圍環境，在更換時，請鋪上報紙。
- 舊的過濾網，請根據居住地區的垃圾分類方法進行廢棄處理。
- 由於使用環境的不同，有時候也會發生在數周或數月內，過濾網有異味產生，需要更換過濾網的情況。
- 過濾網是消耗品，保養期內也需要收費。

過濾網更換週期

過濾網名稱	過濾網狀況	更換週期	過濾網型號
HEPA集塵過濾網	覺得吹出的風有異味時	5年	FZ-D40XH
活性炭除臭過濾網	覺得吹出的風有異味時	5年	FZ-D40XD

※根據「日本電機工業會規格JEM1467」標準，以每天燃點5支香煙，脫臭效能比初次使用時減少一半來計算，過濾網的壽命約為5年。如1天內燃點10支香煙，更換週期約為2.5年。實際更換期取決於主機操作時間長短及安裝地點。

故障時的檢查事項

在委託維修之前，請再次進行檢查和確認。



症狀	請進行檢查	參考頁數												
異味	<p>難以去除異味或煙霧</p> <ul style="list-style-type: none"> ● 過濾網是否仍在塑料袋內？ ⇒ 請把過濾網從塑料袋內拿出來。 ● 吹出口吹出的風是否變弱了？ ⇒ 請對下表中帶★記號的地方進行清掃。 <table border="1"> <thead> <tr> <th colspan="4">保養位置</th> </tr> <tr> <th>主機</th> <th>背板</th> <th>活性炭除臭過濾網</th> <th>HEPA集塵過濾網</th> </tr> </thead> <tbody> <tr> <td></td> <td>★</td> <td>★</td> <td>★</td> </tr> </tbody> </table>	保養位置				主機	背板	活性炭除臭過濾網	HEPA集塵過濾網		★	★	★	C - 6 C - 12~13
	保養位置													
	主機	背板	活性炭除臭過濾網	HEPA集塵過濾網										
		★	★	★										
吹出口吹出的風有異味	<ul style="list-style-type: none"> ● 是否在氣味強烈的房間內使用？ 如果在香煙或烤肉等有強烈氣味的環境下使用，在數周或數月內過濾網可能會產生異味，此時可能需要更換過濾網。 ⇒ 建議在使用空氣清新機的同時，經常保持室內空氣流通。 ● 請對下表中帶★記號的地方進行檢查，對產生異味的地方進行清掃。 <table border="1"> <thead> <tr> <th colspan="4">保養位置</th> </tr> <tr> <th>主機</th> <th>背板</th> <th>活性炭除臭過濾網</th> <th>HEPA集塵過濾網</th> </tr> </thead> <tbody> <tr> <td></td> <td></td> <td>★</td> <td>★</td> </tr> </tbody> </table> <ul style="list-style-type: none"> ● 由於PCI產生器在產生PCI時，會同時產生微量的臭氧，所以在吹出口有時會有異味，但只是微量，對健康沒有影響。 	保養位置				主機	背板	活性炭除臭過濾網	HEPA集塵過濾網			★	★	— C - 12~13
保養位置														
主機	背板	活性炭除臭過濾網	HEPA集塵過濾網											
		★	★											
過濾網重設指示燈亮起	<ul style="list-style-type: none"> ● 請對下表中帶★記號地方進行保養。 <table border="1"> <thead> <tr> <th colspan="4">保養位置</th> </tr> <tr> <th>主機</th> <th>背板</th> <th>活性炭除臭過濾網</th> <th>HEPA集塵過濾網</th> </tr> </thead> <tbody> <tr> <td></td> <td>★</td> <td></td> <td></td> </tr> </tbody> </table>	保養位置				主機	背板	活性炭除臭過濾網	HEPA集塵過濾網		★			C - 12
保養位置														
主機	背板	活性炭除臭過濾網	HEPA集塵過濾網											
	★													
過濾網重設指示燈不熄滅	<ul style="list-style-type: none"> ● 是否已經按了重設鍵？ ⇒ 在清潔保養後，請持續按重設鍵3秒或以上。 	C - 12												
從主機中發出“噠~”的聲音。	<ul style="list-style-type: none"> ● 產生PCI時的聲音，並非異常。聲音的大小將會視乎不同的使用環境和操作模式而有所不同，有時也會基本上聽不到，並不會影響PCI本身的效能。 	—												

症狀	請進行檢查	參考頁數
異味・塵埃監測器	<p>塵埃監測器或異味監測器指示燈沒有切換？</p> <ul style="list-style-type: none"> ● 運行剛開始時，感測器的靈敏度有機會比較不穩定，以致異味監測器指示燈的顏色沒有切換。經過數分鐘的運行後，感測器的靈敏度將會穩定。 ⇒ 但此時若感覺靈敏度還是不穩定時，請對靈敏度進行調整。 ● 在指示燈變綠以後不再變化的情況下，表示空氣一直處於清潔狀態。由於異味發出的位置不同，有時候可能會發生監測較為困難的情況。在向感測器燃點香煙或在周圍拍打毛巾時，若異味監測器、塵埃監測器的顏色發生變化則屬於正常。 ● 在室內有較強烈異味的情况下插入電源插頭開始運行，有時會發生異味感測器靈敏度下降的情況。 ⇒ 將空氣淨化運行設定在「MED」(標準)度風速下運行數小時至一天。 ● 有時候會發生感測器的靈敏度與房間狀態不相配的情況。 ⇒ 請停止運行，重新對靈敏度進行調整。 	C - 11 — — C - 11
	<p>塵埃監測器或異味監測器指示燈始終不變綠色？</p> <ul style="list-style-type: none"> ● 由於房間的窗或門經常打開，使外部的髒污進入，在氣密性較差的房間內，淨化房間(指示燈變綠)需要一定的時間。 	—
	<p>塵埃監測器或異味監測器指示燈頻繁切換？</p> <ul style="list-style-type: none"> ● 由於房門經常開關，可能會因風和急劇的溫度變化引起反應。 	—
	<p>指示燈刺眼</p> <ul style="list-style-type: none"> ● 可按「指示燈亮度調校」鍵調校指示燈亮度。 	C - 10

規格

型號	FU-D40A		
電源	220-240V 50/60Hz		
適用面積(平方米)	31		
風速模式	低(LOW)	中(MED)	高(HIGH)
空氣流量(立方米/小時)	80	200	250
額定耗電量(瓦)	4.6	14.2	29.0
噪音(分貝)	27.3	41.1	46.5
外形尺寸(毫米)	357(闊)×201(深)×576(高)		
重量(公斤)	約5.5		
電源線長度(米)	1.8		

更換用過濾網(零售部品)

過濾網名稱	過濾網型號
HEPA集塵過濾網	FZ-D40XH
活性炭除臭過濾網	FZ-D40XD

注意： HEPA集塵過濾網的壽命約為5年。

活性炭除臭過濾網的壽命約為5年*。

過濾網的具體保養方法詳見使用說明書。

C-12, 13, 15

※ 活性炭除臭過濾網壽命的計算依據：

根據「日本電機工業會規格JEM1467」標準，以每天燃點5支香煙，脫臭效能比初次使用時減少一半來計算，過濾網的壽命約為5年。如1天內燃點10支香煙，更換週期約為2.5年。

實際更換期取決於主機操作時間長短及安裝地點。

由於使用環境的不同，有時候也會發生在數周或數月內，過濾網有異味產生，需要更換過濾網的情況。